

# AWR5

## "TEDDY" PLANETARY STIRRING AND BEATING UNIT



■  
Stirring bowl with  
5 litre capacity

■  
Kitchens

■  
Bakeries

■  
Laboratories



### SEVEN STANDARD COLOURS

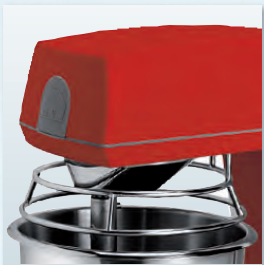

Red



White



Grey



Black

- Powerful beating, kneading and stirring Versatile, movable table model
- Attractive, ergonomic design
- Simple handling with multi-functional switch
- Hygienic, easy-to-clean stainless steel tools Stirring bowl with lid; 5 litre capacity
- Powerful 500 watt motor with overload protection
- Infinitely variable speed control
- Very low noise emission

## SELECTION OF ACCESSORIES



Stainless steel stirring bowl  
stackable and fitted with  
white plastic lid



Beating whisk,  
including stainless steel wires  
2.5 mm



Kneader, stainless steel



Stirrer, stainless steel

## TECHNICAL DATA

Capacity (l)	5
Power supply	230 V, 50/60 Hz, 1.5 m cable with CEE Euro plug
Output (kW)	0.5
Infinitely variable speed control (rpm)	78-422
Dimensions (L x W x H)	240 x 462 x 400 mm (max. 550 mm)
Weight (kg)	18
Reduced bowl size (l)	-

Plastic splash guard  
Without illustration

Feeding chute  
Without illustration

AWR5 „Teddy“

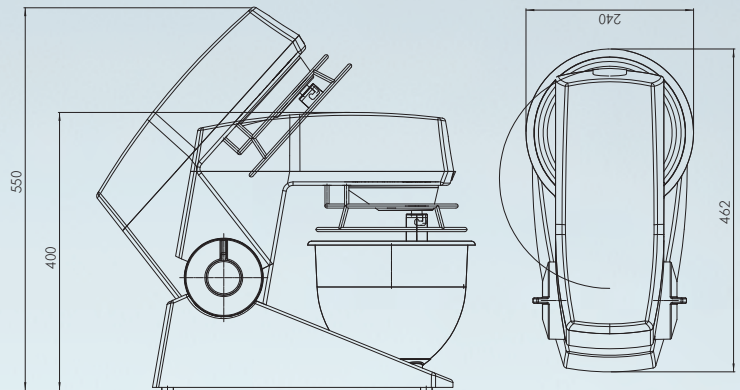

## PROCESSING CAPACITY

Product	Tool	Max. quantity
Bread dough (50%) (kg)	Kneader	2.5
Cake Base (kg)	Stirring whisk	1
Egg whites (l)	Stirring whisk	0.7
Madeira cake / muffins (kg)	Stirrer	2.5
Mayonnaise (l)	Stirring whisk	4.4
Mashed potatoes (kg)	Stirring whisk	2.5
Cream (l)	Stirring whisk	1.5

The figures shown here are for illustration only and may deviate from the actual design version. Technical alterations are reserved. For additional accessories please refer to our price list.