

Universalmaschine G 450 Universal Food Processor G 450



| Bestellnummer Order number | Beschreibung Description | Flügel Wing | Schaltstufe Setting | Anwendung Use |
|-------------------------------|-----------------------------|----------------|------------------------|------------------|
|-------------------------------|-----------------------------|----------------|------------------------|------------------|

Passieren / Straining

Schneidezylinder / Cutting cylinder

| | | | | |
|--|------------|--------|---|--|
|  | 5450003410 | 1,5 mm | Doppelflügel Double wing 5450003500 | II = schnell II = fast Suppen, Soßen, Kompotte Soups, sauces, stewed fruits |
| | 5450003430 | 3 mm | | |

Pürieren / Puréeing

Pürierzylinder / Puree cylinder

| | | | | |
|--|------------|--|---|--|
| | 5450003440 | | Standardflügel Standard wing 5450003300 oder/or Doppelflügel Double wing 5450003500 | II = schnell II = fast Gekochte Kartoffeln für Püree, mehlig Kartoffeln abgedampft und möglichst heiß verarbeiten, gleich heiße Milch hinzugeben Boiled mealy potatoes for purée: let steam evaporate and process while still as hot as possible; immediately add hot milk |
|--|------------|--|---|--|

Würfeln / Dicing

Würfelflügel / Dicing wing

| | | | | |
|--|------------|----------|--|---|
|  | 5450005420 | 8/11 mm | | I = langsam I = slow Möhren, Karotten, Kartoffeln, Zwiebeln, Sellerie, rote Beete, Essiggurken Carrots, potatoes, onions, celery, beetroot, gherkins |
| | 5450005520 | 16/22 mm | | |

Würfeltrommel / Dicing drum

| | | | | |
|--|------------|-------|--|---|
|  | 5450005310 | 8 mm | | I = langsam I = slow Möhren, Karotten, Kartoffeln, Zwiebeln, Sellerie, rote Beete, Essiggurken Carrots, potatoes, onions, celery, beetroot, gherkins |
| | 5450005410 | 11 mm | | |
| | 5450005510 | 16 mm | | |

Würfelschneidezylinder / Dicing and cutting cylinder

| | | | | |
|---|------------|-------|--|---|
|  | 5450005330 | 8 mm | | I = langsam I = slow Möhren, Karotten, Kartoffeln, Zwiebeln, Sellerie, rote Beete, Essiggurken Carrots, potatoes, onions, celery, beetroot, gherkins |
| | 5450005430 | 11 mm | | |
| | 5450005530 | 16 mm | | |
| | 5450005630 | 22 mm | | |

Reinigungsgeräte / Cleaning devices

| | | | | |
|--|------------|----------|--|--|
| | 5530000398 | 8/16 mm | | |
| | 5530000399 | 11/22 mm | | |

Weitere Zylinder und Scheiben auf Anfrage. / More cylinders and discs on enquiry.



Technische Daten

| | |
|--|--|
| Anschluss | 400V, 50 Hz ¹ 3 m langes Kabel mit CEE-Stecker |
| Leistung (kW) | 1,8/3,6 ² |
| Elektrische Absicherung (A) | 16 |
| Schutz der elektrischen Einrichtung | Eingebaute Wicklungsschutz kontakte und Maschinen- schutzschalter VDE-Vorschrift / Schutzart IP 54 (spritzwassergeschützt) |
| Zwei Geschwindigkeitsstufen | (U/min) 150/300 |
| Durchsatzleistung (kg/h) | 2000 z. B. Reiben von rohen Kartoffeln 3000 z. B. Krautschneiden 3000 z. B. Streifenschneiden 3000 z. B. Rohkosten von Karotten 3000 z. B. Würfeln 4000 z. B. gekochte Kartoffeln |
| B x H x T mm | 630 x 1310 x 1310 |
| Durchmesser der 4 Rollen mm | 100 |

¹Wartungsfreier polumschaltbarer Drehstrommotor, Keilriemen- und Kesselradgetriebe, Antrieb mit Arbeitsbehälter und Kegelradgetriebe.

²Einschließlich thermischem Überlastungsschutz, weitere Spannungen auf Anfrage.

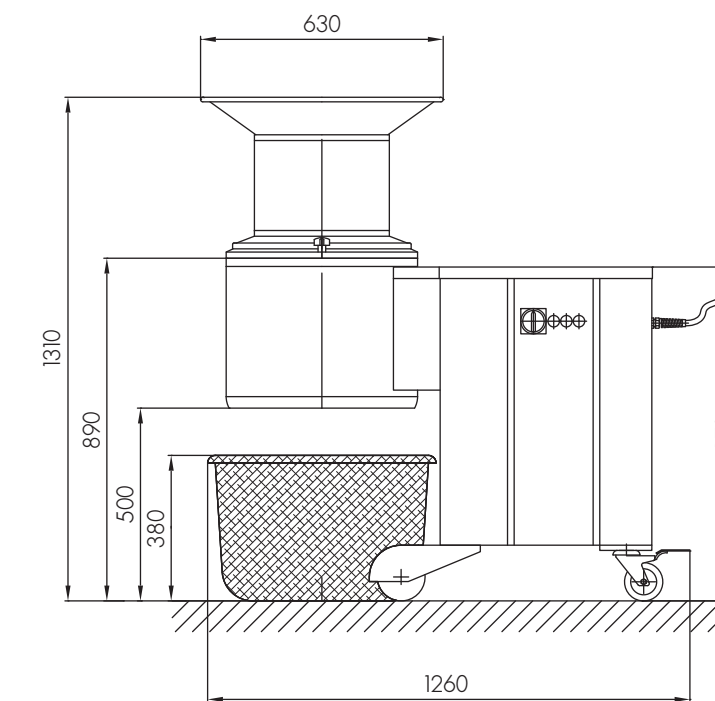

D-GB/FEB/2008/2000/OV/BU

Technical Data

| | |
|--|--|
| Power supply | 400V, 50 Hz ¹ 3 m long cable with CEE plug |
| Wattage (kW) | 1.8/3.6 ² |
| Fuse protection (A) | 16 |
| Protection for electrical unit | Built-in shockproofing on coil and machine safety switch VDE-regulation/IP 54 protection system (splash-proof) |
| Two speed settings (rpm) | 150/300 |
| Operational capacity (kg/h) | 2000 e.g. grating raw potatoes 3000 e.g. cutting cabbage 3000 e.g. cutting into strips 3000 e.g. raw carrot dishes 3000 e.g. dicing 4000 e.g. boiled potatoes |
| W x H x D mm | 630 x 1310 x 1310 |
| Diameter of the four castors mm | 100 |

¹No-maintenance pole-changing three-phase AC motor, V-belt and bevel gears, drive with processor bowl and bevel gears.

²Including thermal overload protection, other wattages on enquiry.

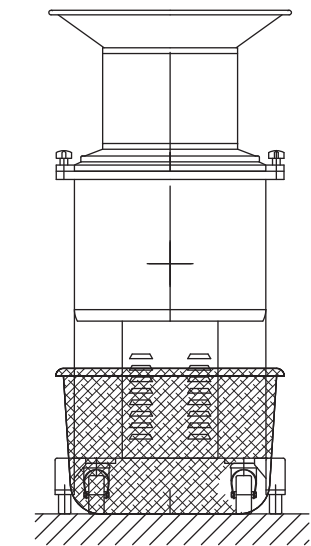

Die CAD-Zeichnung zeigt die Universalmaschine G 450.
CAD drawing shows G 450 universal cutter.



Reif die Leistung, flexibel der Einsatz

Wer glaubt, Würfeln, Schnitzeln, Reiben, Passieren und Schneiden seien niemals mit nur einer Maschine zu erledigen, sollte unsere G 450 einmal in Aktion erleben. Vorzugsweise in Fernküchen, Mensen, Kantinen und Krankenhäusern. Natürlich auch in der Feinkost- und Konservenindustrie. Eben überall da, wo große Mengen verarbeitet werden müssen. Dort beweist sie täglich, was in ihr steckt und was sie kann. Mehr als 100 Verarbeitungsmöglichkeiten, sowie auch ihre grundsätzliche Verarbeitung selbst sprechen für sich und für das universelle Konzept unserer Entwicklungsingenieure.

High on performance and versatility

Anyone who thinks dicing, shredding, grating, straining and cutting can never be executed by a machine should take a look at our G450 in action. Preferably in an industrial kitchen, university canteen, workplace kitchen or hospital. Naturally, there are also plenty of them in use in the delicatessen and preserved-food industry – in fact, wherever large quantities have to be processed. This machine will show you what it is capable of day after day. More than 100 processing options and a rock-solid construction speak for themselves, and for the universal concept of our development engineers.



Auf einen Blick

- Ideal ab 600 Essen
- Robuste Maschinenausführung; Maschinenverkleidung aus rostfreiem Edelstahl
- Bearbeitungswerkzeuge aus rostfreiem Edelstahl
- Durchsatzleistung bis zu 4000 kg/h
- Automatische Zu- und Abführung möglich
- Variable Zylinderbestückung, mehr als 100 Reib-, Würfel-, Passier- und Schnitzel-Arten zur Verfügung
- 500 mm lichte Höhe zum Unterstellen der Auffanggefäße
- Fahrbar durch 4 Fahrrollen
- Sicherheitsabschaltung
- Wahlschalter für 2 Geschwindigkeiten 150/300U/min, EIN-AUS-Taste
- Optional: komplett in Edelstahl rostfrei

At a Glance



- Ideal for 600+ servings
- Stable machine design; machine casing made of high-grade stainless steel
- Processing tools of high-grade stainless steel
- Operational capacity of up to 4000 kg/h
- Automatic in- and outfeed possible
- Variable cylinder equipment: more than 100 possible ways to cut, grate, dice, strain and shred
- 500 mm headroom for the container to collect the product
- Movable on four castors
- Safety cutoff
- Dial to select two speeds: 150/300 rpm, ON-OFF button
- Optional: entire unit in high-grade stainless steel

- 1 Universalaufsatz
- 2 Bedienfeld für zwei Geschwindigkeitsstufen
- 3 Zwei Standardwerkzeuge
- 4 Arbeitsbehälter
- 5 Grundmaschine
- 6 2x Rollen (lenkbar mit Feststellern(bremsel))
- 7 2x Rollen (fest)

- 1 Universal attachment
- 2 Dial for two speed settings
- 3 Two standard tools
- 4 Container
- 5 Basic machine
- 6 2x castors (steerable with locks/brakes)
- 7 2x castors (fixed)

| Bestellnummer Order number | Beschreibung Description | Flügel Wing | Schaltstufe Setting | Anwendung Use |
|-------------------------------|-----------------------------|----------------|------------------------|------------------|
|-------------------------------|-----------------------------|----------------|------------------------|------------------|

Flügel / Blades

| | | | | |
|---|------------|--|--|--|
|  | 5450003500 | Doppelflügel/Double wing | | |
| | 5450003400 | Sonderflügel A ¹ /Special wing A ¹ | | |
|  | 5450003300 | Standardflügel/Standard wing | | |

Schneiden / Cutting

Schneidezylinder / Cutting cylinder

| | | | | | |
|---|------------|--|-------------------------------|---------------------------|--|
|  | 5450003820 | 2 mm, mit verzahnten Messern/ With saw blades | Doppelflügel Double wing | II = schnell II = fast | Kraut (Kohl, kein Sauerkraut), Wirsing bevorzugt Zylinder 5450003840 oder 5450003860 |
| | 5450003825 | 2,5 mm | 5450003500, Sonderflügel A | | Cabbage (not sauerkraut), savoy ideally cylinder 5450003840 or 5450003860 |
| | 5450003840 | 4 mm | Special wing A | | |
| | 5450003860 | 6 mm | 5450003400 | | |

Scheibenschneiden / Slicing discs



Schneidezylinder / Slicing cylinder

| | | | | | |
|--|------------|------|---------------------------------|---------------------------|--|
| | 5450003830 | 4 mm | Standardflügel Standard wing | I = langsam I = slow | Gekochte Kartoffeln (4 mm oder 6 mm) Boiled potatoes (4 mm or 6 mm) |
| | 5450003840 | 4 mm | Standardflügel Standard wing | II = schnell II = fast | Knödelbrot, Scheiben allgemein Dumplings, round slices in general |
| | 5450003870 | 6 mm | Standardflügel Standard wing | I = langsam I = slow | Gekochte Kartoffeln (4 mm oder 6 mm) Boiled potatoes (4 mm or 6 mm) |
| | 5450003860 | 6 mm | Standardflügel Standard wing | II = schnell II = fast | Knödelbrot, Scheiben allgemein Dumplings, round slices in general |

Universalschneidezylinder mit Messerblock / Universal cutting cylinder with knife block

| | | | | | |
|---|------------|--|--|--|---|
|  | 5450003510 | Universalschneidezylinder Universal cutting cylinder | Standardflügel Standard wing | I = langsam I = slow | Tomaten, Rote Beete, Sellerie Tomatoes, beetroot, celery |
| | 5450003570 | 4 mm Buntschnittmesserblock Block of crinkle cut knives | 5450003300 oder/or Doppelflügel Double wing | II = schnell II = fast | |
| | 5450003560 | 6 mm Tomatenschneidmesserblock Tomato-cutting knife block | 5450003500 | Rote Beete, Sellerie: Buntschnittform Beetroot, celery: Crinkle cut | |

Rohraufsatz / Tube attachment

| | | | | | |
|---|------------|---|--|---------------------------|--|
|  | 5450003600 | Möhreneinsatz für Rohraufsatz zur Durchmesserreduzierung Carrot liner reduce diameter of tube | | II = schnell II = fast | Schlangengurken/Cucumbers |
| | 5450003660 | Ø 40 mm reduziert/reduced | | | Möhren/Carrots |
| | 5450003670 | Ø 60 mm reduziert/reduced | | | Möhren/Carrots |
|  | 5450003700 | Bogenmesserschleibe 0–10 mm, verstellbar Curved blade 0–10 mm, adjustable | | | Gerader, geführter Schnitt Straight, guided cutting |



| Bestellnummer Order number | Beschreibung Description | Flügel Wing | Schaltstufe Setting | Anwendung Use |
|-------------------------------|-----------------------------|----------------|------------------------|------------------|
|-------------------------------|-----------------------------|----------------|------------------------|------------------|

Streifenschneiden / Slicing sticks

Streifenschneidezylinder / Stick-slicing cylinder

| | | | | | |
|---|------------|--------------|-----------------------------|---------------------------|--|
|  | 5470009920 | 2 x 2 mm | Doppelflügel Double wing | II = schnell II = fast | Sellerie, Strohkartoffeln, Rote Beete, Möhren und andere, feine Streifen- produkte |
| | 5470009925 | 2,5 x 2,5 mm | 5450003500 | | Celery, straw potatoes, beetroot, carrots and other products in fine sticks |
| | 5470009930 | 3 x 3 mm | | | |
| | 5470009940 | 4 x 4 mm | | | |

Universalschneidezylinder / Universal cutting cylinder

| | | | | | |
|---|------------|---|---------------------------------|---------------------------|--|
| | 5450003510 | Universalschneidezylinder Universal cutting cylinder | Standardflügel Standard wing | II = schnell II = fast | Suppeneinlagen (6; 8; 11 mm) Kartoffeln, Sellerie, Kohlrabi |
|  | 5450003520 | 6 mm Messerblock/Knife block | 5450003300 oder/or | | Garnishes (6; 8; 11 mm), potatoes, celery, turnips |
| | 5450003530 | 8 mm Messerblock/Knife block | Doppelflügel Double blade | | |
| | 5450003540 | 11 mm Messerblock/Knife block | 5450003500 | | |

Rohkosten / Raw vegetables

Rohkostzylinder geschärft / Raw vegetable cylinder sharpened

| | | | | | |
|--|------------|-------------------|---------------------------------|---------------------------|---|
| | 5450003370 | 2 mm, fein/fine | Standardflügel Standard wing | II = schnell II = fast | Karotten, Sellerie, Möhren Carrots, celery |
| | 5450003360 | 3 mm | 5450003300 oder/or | | |
| | 5450003365 | 4 mm, grob/coarse | Doppelflügel Double wing | | |
| | | | 5450003500 | | |

Schnitzeln / Shredding

Schnitzelzylinder / Shredding cylinder

| | | | | | |
|--|------------|-------------------|---------------------------------|---------------------------|--|
| | 5450003340 | 6 mm, fein/fine | Standardflügel Standard wing | II = schnell II = fast | Karotten, Möhren, Rettich etc. Carrots, radishes etc. |
| | 5450003350 | 9 mm, grob/coarse | 5450003300 oder/or | | |
| | | | Doppelflügel Double wing | | |
| | | | 5450003500 | | |

Reiben / Grating

Reibezyylinder / Grating cylinder

| | | | | | |
|---|------------|--|----------------------------------|---------------------------|--|
|  | 5470009450 | 2 mm, feinst/extra fine | Doppelflügel Double wing | II = schnell II = fast | Hartes Brot, gekochte Kartoffeln, Schokolade |
| | 5450003320 | 3 mm, fein/fine | 5450003500 | | Hard bread, boiled potatoes, chocolate |
| | 5450003330 | 2 mm, kronenverzahnt Toothed | | | Rohe Kartoffeln für Klöße und Reibekuchen Raw potatoes for dumplings and potato fritters |
| | 5450003480 | Reibekuchenzylinder Potato fritter cylinder | | | |
| | 5470009450 | feinst/extra fine | Sonderflügel A Special wing A | | Haselnüsse, Walnüsse, Paranüsse Hazelnuts, walnuts, Brazil nuts |
| | 5470009320 | fein/fine | 5450003400 oder/or | | |
| | 5470009310 | grob/coarse | Doppelflügel Double wing | | |
| | | | 5450003500 | | |

¹ Der Sonderflügel A entspricht dem Doppelflügel, er ist jedoch zusätzlich mit einem Rand ausgeführt. Dadurch wird sichergestellt, dass das zu schneidende Gut vollständig durch die Zylinderöffnungen getrieben wird.
² Special wing A is the same as the double wing but comes with a rim to ensure that the material to be cut is pushed all the way through the cylinder openings.

